

Sleeve sensor with temperature measuring transducer, Bluetooth-enabled, with EtherCATP port

Networkable sleeve temperature measuring transducer **THERMASGARD® HFTM-EtherCATP** with M8 plug-in connector (EtherCATP-encoded), Bluetooth-enabled, in an impact-resistant plastic housing with quick-locking screws, optionally with /without display and bar graph, cable sensor with stainless steel sleeve.

The sleeve sensor is used to detect the temperature in liquid and gaseous media. It is used as a duct sensor or, if installed in an immersion sleeve **THE** (accessory), as an immersion and screw-in sensor in liquids. The sensor is factory-calibrated.

EtherCATP-enabled measuring transducer for industrial requirements with maximum reliability: includes easy PLC integration using the device's ESI configuration file, diagnostics (such as communication failure counter), advanced settings options, access to historical data (min / max) and establishing the sensor's service interval. Optionally with large illuminated display (3-line, customised programming in the 7-segment and dot-matrix range) and bar graph (7-digit, LEDs freely configurable) for graphical display, e.g., as a traffic light indicator.

HFTM-EtherCATP



EtherCATP
Cable connection and LED status display

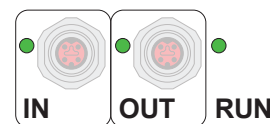

TECHNICAL DATA	
Power supply:	24 V DC via EtherCATP (U _S)
Power consumption:	< 3 W
Bus protocol:	EtherCAT
Radio technology:	Bluetooth (LE)
Sensor:	Pt1000, DIN EN 60751, class B (Perfect Sensor Protection at IP68)
Measuring range:	-50...+150 °C; T_{max} up to +150 °C
Accuracy in temperature:	typically ±0.2 K at +25 °C
Medium:	clean air and non-aggressive, non-combustible gases; liquids depending on selected immersion sleeve (accessory)
Sensor protection:	sensor sleeve made from stainless steel V4A (1.4571), Ø = 6 mm, nominal length (NL) = 50 mm (optional 30...400 mm)
Sensor cable:	Silicone, SiHF, 2 x 0,25 mm ² ; cable length (KL) = 1.5m (other lengths and jacket materials, e.g. PTFE or glass fibre with steel mesh, available on request)
Housing:	Plastic, UV-resistant, polyamide material, 30% glass-globe reinforced, with quick-locking screws (slotted / Phillips head combination), colour traffic white (similar to RAL 9016), housing cover for display is transparent!
Housing dimension:	126 x 90 x 50mm (Tyr 2)
Cable connection:	M8 plug-in connector , EtherCATP-encoded
Ambient temperature:	measuring transducer -30...+70 °C
Permitted humidity:	< 95% RH, non-precipitating air
Protection class:	III (according to EN 60 730)
Protection type housing:	IP 54 (according to EN 60 529)
Protection type sensor:	IP 65 (according to EN 60 529) sleeve humidity-tight (standard) IP 68 (according to EN 60 529) sleeve water-tight (optional) IP 54 (according to EN 60 529) with glass fibre cable (optional)
Standards:	CE conformity, according to EMC Directive 2014 / 30 / EU, according to RED 2014 / 53 / EU
Equipment:	Display with illumination , 3-line, customised programming, cutout approx. 51 x 29 mm, to display the actual temperature or a customised display value. Bar graph , 7-digit, LEDs freely configurable, to graphically display the reading.

ACCESSORIES	
EtherCAT P	LED status display
1. LED	"IN"
off	no connection to upstream EtherCAT module
illuminated	LINK: connection to upstream EtherCAT module
blinking	ACT: communication with upstream EtherCAT module
2. LED	"OUT"
off	no connection to downstream EtherCAT module
illuminated	LINK: connection to downstream EtherCAT module
blinking	ACT: communication with downstream EtherCAT module
3. LED	"RUN"
off	EtherCAT module is in "Init" state
quickly blinking	EtherCAT module is in "Pre-Operational" state
slowly blinking	EtherCAT module is in "Safe-Operational" state
illuminated	EtherCAT module is in "Operational" state

The status LEDs are next to the cable connection.

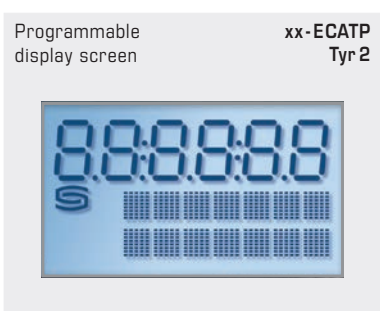
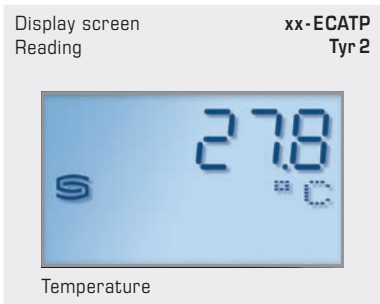



S+S REGELTECHNIK

THERMASGARD® HFTM - EtherCAT P

Sleeve sensor with temperature measuring transducer,
Bluetooth-enabled,
with EtherCAT port

Dimensional drawing

HFTM - EtherCAT P

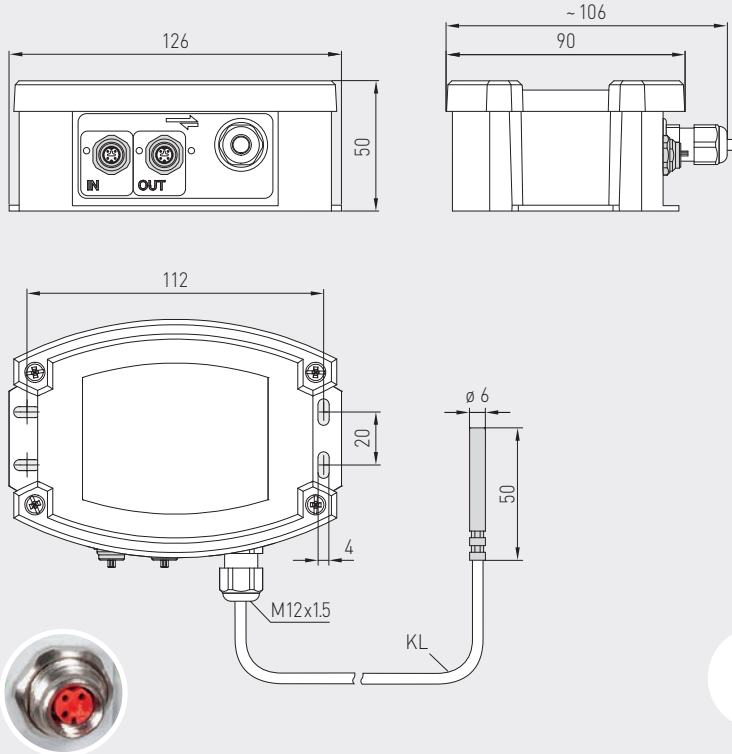

M8-plug-in connector
EtherCAT P-encoded



HFTM - EtherCAT P
with display and bar graph



IP65 (standard)
humidity-tight

IP68 (optional)
watertight
Perfect Sensor Protection

IP54 (optional)
with glass fibre cable

High-performance encapsulation against
vibration, mechanical stress and humidity

PS-PROTECTION
PERFECT SENSOR PROTECTION

THERMASGARD®
HFTM - EtherCAT P

Sleeve sensors with temperature measuring transducer
with EtherCAT P port

Type / WG02	Measuring Range Temperature	Sensor	Output	Bar graph Display	Item No.	Price
HFTM-ECATP xx						
HFTM-ECATP	-50...+150 °C	Pt1000	EtherCAT P		2001-2161-9100-001	379,75 €
HFTM-ECATP LCD	-50...+150 °C	Pt1000	EtherCAT P	☐ ■	2001-2162-9100-001	429,28 €
Note:	Cable connection with M8 plug-in connector (EtherCAT P-encoded)					
Extra charge:	Protection type IP68 (sensor sleeve watertight compound-filled) per running metre of connecting lead (silicone/PTFE/glass fibre) other protection sleeve lengths (optional 30...400 mm)				on request on request	3,64 €

ACCESSORIES

THE-xx Immersion sleeve, stainless steel V4A (1.4571) or nickel-plated brass, Ø = 9 mm
Inner diameter of socket 5.2 mm, with **adjusting screw** M12 x1.5

For further information, see last chapter Accessories!