

On-wall radiation temperature sensors with passive output

ASTF

Resistance thermometer **THERMASGARD® ASTF** with passive output, terminal box housing made of impact-resistant plastic and housing cover with quick-locking screws. This radiation sensor is specifically designed for temperature detection in wet areas or in larger rooms or halls. The on-wall radiation temperature sensor ASTF determines the effective portion of active radiation or the effective radiant heat at the measured location. Due to the measuring method employed by the dark radiation temperature sensor, excellent and room-representative measuring results are achieved.



TECHNICAL DATA

Measuring range:	-30 ...+ 75 °C
Sensors / output:	see table, passive (optional also with two sensors)
Connection type:	2-wire connection (4-wire connection on PT100, optional on other sensors)
Testing current:	< 0.6 mA (Pt1000) < 1.0 mA (Pt100) < 0.3 mA (Ni1000, Ni1000 TK5000) < 2.0 mW (NTC xx) 400 µA...5 mA (LM235Z)
Insulating resistance:	≥ 100 MΩ, at +20 °C (500 V DC)
Process connection:	by screws
Housing:	plastic, UV-resistant, material polyamide, 30% glass-globe reinforced, with quick-locking screws (slotted / Phillips head combination), colour traffic white (similar to RAL 9016), semi-globe: black
Housing dimensions:	72 x 64 x 37.8 (51.8) mm (Tyr 1)
Cable connection:	cable gland , plastic (M16 x 1.5; with strain relief, exchangeable, max. inner diameter 10.4 mm) or M12 connector according to DIN EN 61076-2-101 (optional on request)
Electrical connection:	0.14 - 1.5 mm², via terminal screws
Humidity:	< 95 % RH
Protection class:	III (according to EN 60 730)
Protection type:	IP65 (according to EN 60529) Housing tested, TÜV SÜD, Report No. 713139052 (Tyr 1)

Dimensional drawing

ASTF

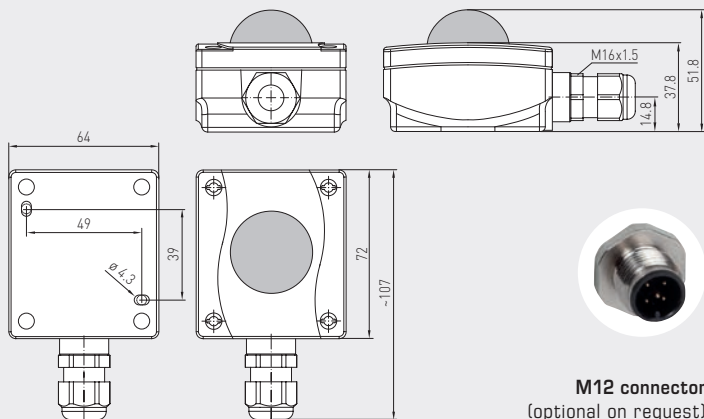

M12 connector
(optional on request)

1x two-wire connection standard

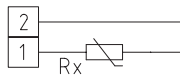

1x two-wire connection LM235Z (KP 10)

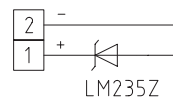

1x three-wire connection (optional)

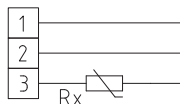

1x four-wire connection (optional)

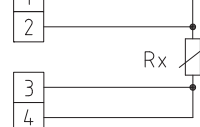

THERMASGARD® ASTF On-wall radiation temperature sensors

Type / WG03	Sensor / Output	Item No.	Price
ASTF		IP65	
ASTF Pt100	Pt100 (according to DIN EN 60 751, B)	1101-1060-1003-000	75,50 €
ASTF Pt1000	Pt1000 (according to DIN EN 60 751, class B)	1101-1060-5001-000	75,50 €
ASTF Ni1000	Ni1000 (according to DIN EN 43 760, class B, TCR = 6180 ppm / K)	1101-1060-9001-000	76,84 €
ASTF NiTK	Ni1000 TK5000 (TCR = 5000 ppm / K), LG- Ni1000	1101-1061-0001-000	79,37 €
ASTF LM235Z	LM235Z (TCR = 10 mV / K; 2.73 V at 0 °C), KP10	1101-1062-1001-000	74,11 €
ASTF NTC1,8K	NTC 1.8K	1101-1061-2001-000	79,37 €
ASTF NTC10K	NTC 10K	1101-1061-5001-000	79,37 €
ASTF NTC20K	NTC 20K	1101-1061-6001-000	79,37 €
Extra charge:	two or other sensors optional cable connection with M12 connector according to DIN EN 61076-2-101		on request on request