

**Surface contact / tube contact temperature measuring transducers, incl. strap, with detached sensor head, calibratable, with multi-range switching and active output (Automatic Output Switching)**

**Patented quality product** (patent no. DE 10 2015 015 941 B4)

Calibratable tube contact temperature measuring transducer **THERMASGARD® ALTM 2 - VA**, with eight switchable measuring ranges (max. -20...+150 °C), active output, external sensor, incl. strap, rugged housing made from **stainless steel V4A**, with cable gland or M12 connector according to DIN EN 61076-2-101.

The measuring transducer converts the measured variables into a standard signal of 0- 10 V or 4...20 mA. The unit with **Automatic Output Switching** (AOS variant) detects the required output type and automatically switches to U or I output. Alternatively, a **type version** (2-wire I variant) with 2-wire connection and I output is available.

The surface-contact sensor is used for temperature detection on lines, pipes (e.g. cold and hot water) or on heating sections for heating system control. The sensor is factory-calibrated; an environmental precision adjustment by an expert is possible.

**TECHNICAL DATA**

**ALTM 2 - I**

Power supply:	15...36 V DC, depending on working resistance, residual ripple stabilised ± 0.3 V
Working resistance:	$R_a \text{ (Ohm)} = (U_b - 14 \text{ V}) / 0.02 \text{ A}$
Connection type:	2-wire connection
Output:	<b>4...20 mA</b>

**ALTM 2 - A (AOS)**

Power supply:	24 V AC / DC (± 10 %)
Load resistance:	$R_L = 25...450 \text{ Ohm}$ with AOS I variant $R_L > 15 \text{ kOhm}$ with AOS U variant
Connection type:	3-wire connection
Output:	<b>automatic 0-10 V / 4...20 mA</b> (via <b>Automatic Output Switching</b> – the unit detects the required output type and automatically switches to U or I output)

**GENERAL**

Power consumption:	< 1.0 VA / 24 V DC; < 2.2 VA / 24 V AC
Measuring ranges:	<b>multi-range switching with 8 measuring ranges</b> , see table (other ranges optional) <b>T<sub>max</sub> up to +100 °C</b> , operating range -50...+150 °C <b>with manual zero point correction (± 10 K)</b>
Sensor:	Pt1000, DIN EN 60751, class B <b>(Perfect Sensor Protection)</b> at IP68
Accuracy, temperature:	typically ± 0.2 K at +25 °C
Insulating resistance:	≥ 100 MΩ, at +20 °C (500 V DC)
Sensor protection:	pipe feeder made of stainless steel <b>V4A</b> (1.4571), Ø = 6 mm, L = 50 mm
Sensor cable:	Silicone, SiHF, 2x0.25mm <sup>2</sup> ; cable length (KL) = 1.5m (other lengths and jacket materials, e.g. PTFE or glass fibre with steel mesh, available on request)
Housing:	<b>stainless steel V4A</b> (1.4571), with non-distortion cover bolting, impact resistant, high EMI shielding, corrosion, temperature, weather- and UV-resistant
Housing dimension:	143 x 97 x 61 mm (Tyr 2E)
Cable connection:	<b>cable gland, stainless steel V2A</b> (1.4305) (M20 x 1.5; with strain relief, exchangeable, inner diameter 6 - 12 mm) <b>or</b> <b>M12 connector</b> (male, 5-pin, A-code) according to DIN EN 61076-2-101
Electrical connection:	0.14 - 1.5 mm <sup>2</sup> , via terminal screws
Process connection:	endless strap with metal tightener (included in the scope of delivery) Ø = 13 - 92 mm (¼ - 3"), L = 300 mm
Ambient temperature:	measuring transducer -30...+70 °C
Permissible humidity:	< 95% RH, non-precipitating air
Protection class:	III (according to EN 60 730)
Protection type housing:	<b>IP 65</b> (according to EN 60 529) Housing tested, TÜV SÜD, Report No. 713160960B (Skadi2)
Protection type sensor:	<b>IP 65</b> (according to EN 60 529) <b>sleeve</b> humidity-tight (standard) <b>IP 68</b> (according to EN 60 529) <b>sleeve</b> water-tight (optional)
Standards:	CE conformity according to EMC directive 2014 / 30 / EU

**ACCESSORIES** (see table)



**NEW**

S+S REGELTECHNIK

Thermasgard® **ALTM 2 - VA**

Surface contact / tube contact temperature measuring transducers, incl. strap, with detached sensor head, calibratable, with multi-range switching and active output (Automatic Output Switching)

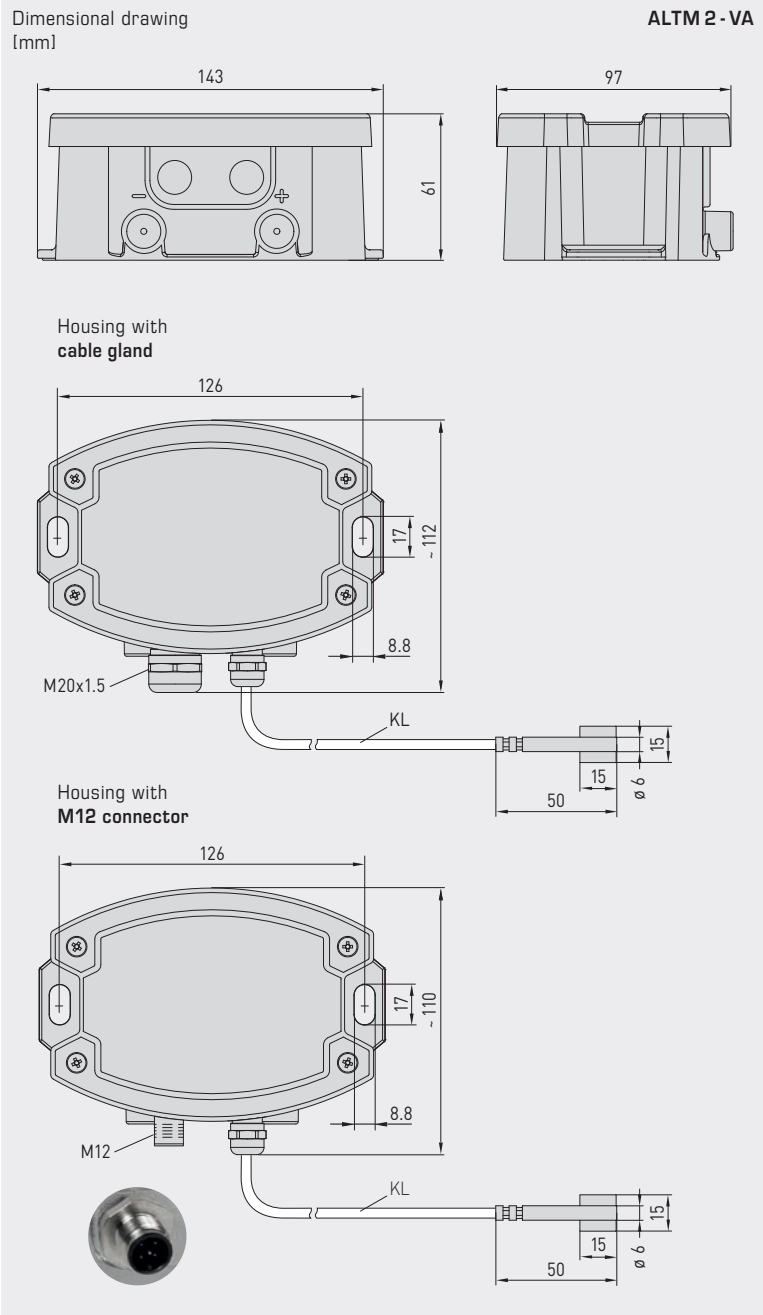

**ALTM 2 - VA**  
with cable gland

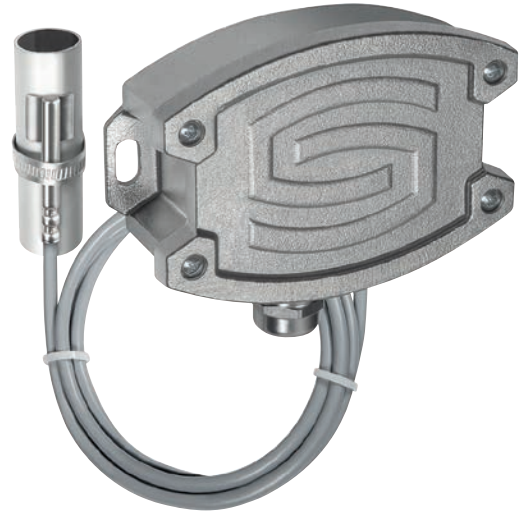

**ALTM 2 - VAQ**  
with M12 connector



High-performance encapsulation against vibration, mechanical stress and humidity

**PS-PROTECTION**  
PERFECT SENSOR PROTECTION

Automatic detection and switching to standard signal 0...10V or 4...20mA

**AOS-PATENTED**  
AUTOMATIC OUTPUT SWITCHING



**IP 65** (standard)  
humidity-tight



**IP 68** (optional)  
water-tight  
Perfect Sensor Protection

Surface contact / tube contact temperature measuring transducers, incl. strap, with detached sensor head, calibratable, with multi-range switching and active output (Automatic Output Switching)

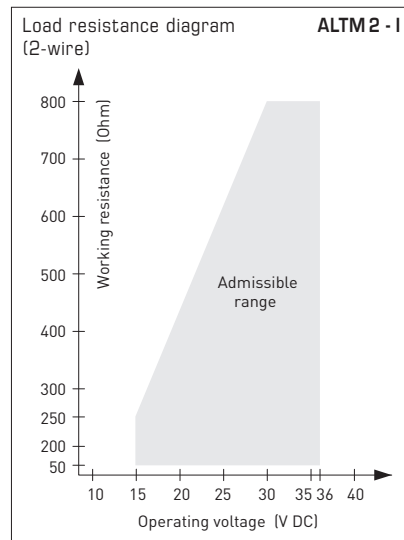
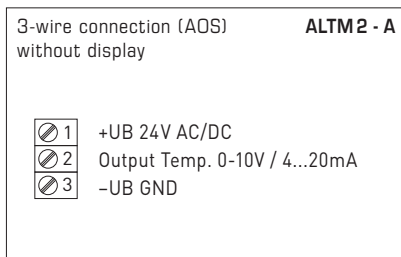
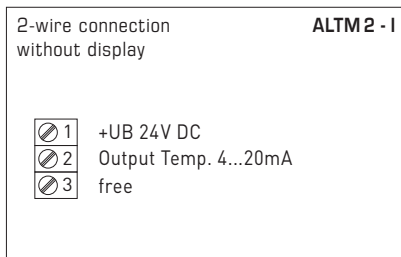
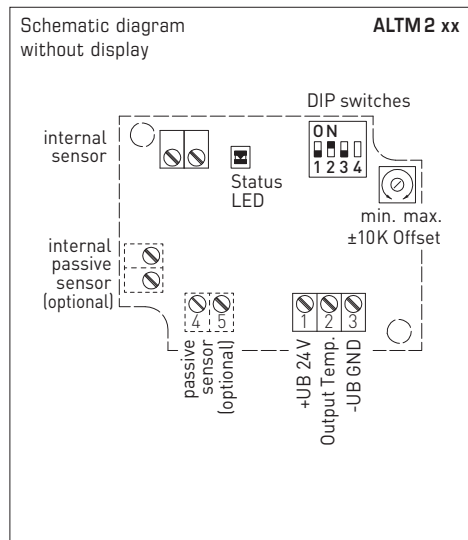

Measuring ranges [°C] (adjustable)	DIP 1	DIP 2	DIP 3
-20...+ 150 °C	ON	ON	ON
-50... + 50 °C	OFF	ON	ON
-20... + 80 °C	ON	OFF	ON
-30... + 60 °C	OFF	OFF	ON
0... + 40 °C	ON	ON	OFF
0... + 50 °C (default)	OFF	ON	OFF
0... + 100 °C	ON	OFF	OFF
0... + 150 °C	OFF	OFF	OFF

DIP4 has no function!

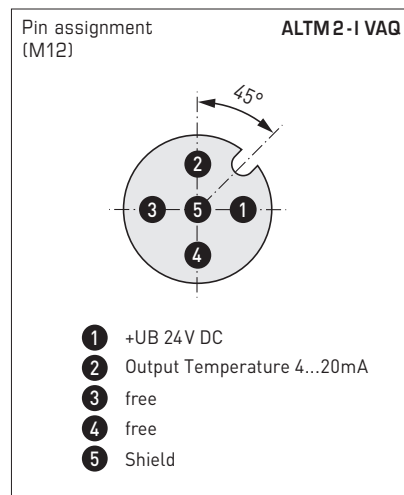
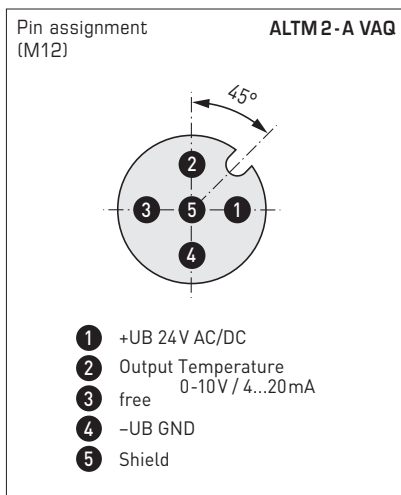

For further technical information, see the operating instructions



NEW

Surface contact / tube contact temperature measuring transducers, incl. strap, with detached sensor head, calibratable, with multi-range switching and active output (Automatic Output Switching)

ALTM 2 - VAQ  
with M12 connector

ALTM 2 - VA  
with cable gland

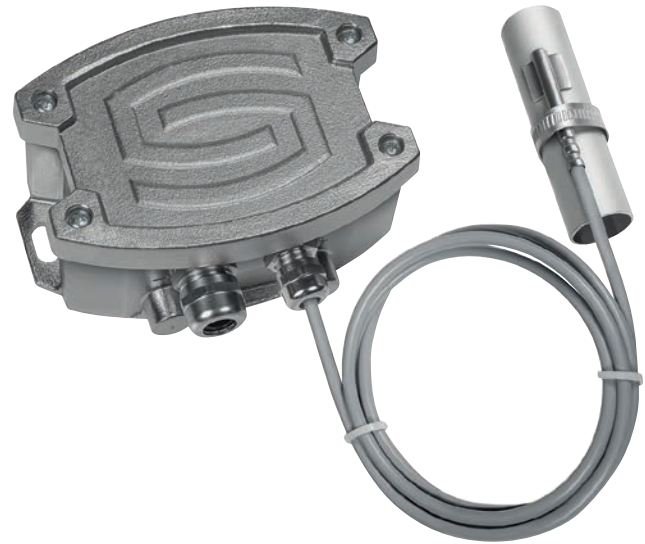

THERMASGARD® ALTM 2 - VA		Surface contact / tube contact temperature measuring transducers, ID (Stainless steel housing with cable gland)		
Type / WG02I	Output	Type	Item No.	Price
<b>ALTM 2 - I VA</b>	<b>(2-wire)</b>			
ALTM2-I VA	4...20 mA	Remote sensor	2001-2151-2200-001	<b>422,71 €</b>
<b>ALTM 2 - A VA</b>	<b>(3-wire AOS)</b>			
ALTM2-A VA	0-10 V / 4...20 mA	Remote sensor	2001-2151-B200-001	<b>422,71 €</b>
<b>Automatic Output Switching (AOS):</b>	Patented analogue interface (patent no. DE 10 2015 015 941 B4) Unit automatically detects the required output type 0-10 V or 4...20 mA.			
<b>Housing variant:</b>	Cable connection with cable gland			
Extra charge:	other measuring ranges optional			<b>27,21 €</b>
	Protection type IP68 (Sensor sleeve watertight compound-filled)			<b>3,64 €</b>
	2-wire connecting leads, per running meter (silicone / PTFE / glass fibre)			on request

THERMASGARD® ALTM 2 - VAQ		Surface contact / tube contact temperature measuring transducers, ID (Stainless steel housing with M12 connector)		
Type / WG02I	Output	Type	● = Q Item No.	Price
<b>ALTM 2 - I VAQ</b>	<b>(2-wire)</b>			
ALTM2-I VAQ	4...20 mA	Remote sensor	● 2001-2151-2100-001	<b>463,99 €</b>
<b>ALTM 2 - A VAQ</b>	<b>(3-wire AOS)</b>			
ALTM2-A VAQ	0-10 V / 4...20 mA	Remote sensor	● 2001-2151-B100-001	<b>463,99 €</b>
<b>Automatic Output Switching (AOS):</b>	Patented analogue interface (patent no. DE 10 2015 015 941 B4) Unit automatically detects the required output type 0-10 V or 4...20 mA.			
<b>Housing variant "Q":</b>	Cable connection with M12 connector (male, 5-pin, A-code)			
Extra charge:	other measuring ranges optional			<b>27,21 €</b>
	Protection type IP68 (Sensor sleeve watertight compound-filled)			<b>3,64 €</b>
	2-wire connecting leads, per running meter (silicone / PTFE / glass fibre)			on request

ACCESSORIES			
<b>WLP-1</b>	Heat-conductive paste, silicone-free	7100-0060-1000-000	<b>4,98 €</b>
	<b>Special accessories for M12 connector</b> see chapter Accessories!		

